

**MGB SERIES (Chip Ferrite Bead for GHz Range) Engineering Specification**



**Features and Application**

- Effectively filtering capability over a wide range of frequency (Several MHz to GHz)
- Monolithic inorganic material construction
- Closed magnetic circuit avoids crosstalk
- Excellent solderability and heat resistance
- High reliability

RF and wireless communication, information technology equipment which includes computer, laptop, telecommunications, radar detectors, automotive electronics, cellular phones, pagers, audio equipment, PDAs, keyless remote system and Navigator systems

**1. PART NUMBER AND CHARACTERISTICS TABLE**

MGB-G Series

Part No.	Impedance( $\Omega$ ) $\pm$ 25% @100MHz	Impedance( $\Omega$ ) $\pm$ 40% @1GHz	DCR( $\Omega$ ) (Max.)	Rated Current (mA)
MGB1005-G Series				
MGB1005G601FBP	600	1400	0.85	300
MGB1005G102YBP	1000	2000	1.25	250
MGB1005G182EBP	1800	2700	2.20	200

\*\* For special part number which is not shown in the above table, please refer to appendix.

Test Instrument : Agilent E4991A RF Impedance / Material Analyzer  
 HP4338A/B Milliohmmeter  
 TOPWARD 33010D DC Power Supply

Test Level : 250 mV

## 2.PART NUMBER CODE

MGB 1005 G 60 1 F B P  
 1        2        3        4        5        6        7        8

- 1 Series Name
- 2 Size Code: the first two digitals : length(mm), the last two digitals : width(mm)
- 3 Material Code
- 4 Impedance( $\Omega$ )  $\pm$  25% } (ex : 601=600 $\Omega$ )
- 5 Fixed Decimal Point }
- 6 Rated Current Code

C=100mA	D=150mA	E=200mA	F=300mA	G=400mA
H=500mA	L=1000mA	M=1500mA	N=2000mA	Y=250mA

- 7 Soldering : Green Parts: A— Soldering Lead-Free    B— Lead-Free for whole chip
- 8 Packaging: P - Embossed paper tape, 7" reel.

## 3.SHAPES AND DIMENSIONS

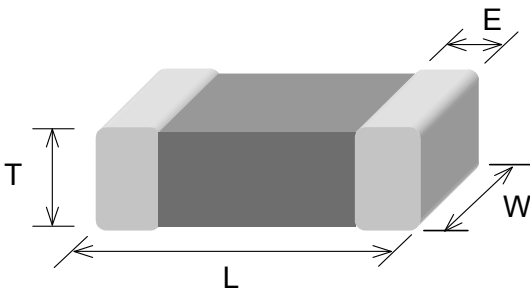

TYPE	100505 (EIA 0402)
L	1.00 $\pm$ 0.10
W	0.50 $\pm$ 0.10
T	0.50 $\pm$ 0.10
E	0.25 $\pm$ 0.10

4. TYPICAL CHARACTERISTIC

**MGB1005G601**

IMPEDANCE vs. FREQUENCY CHARACTERISTICS

INSERTION LOSS vs. FREQUENCY CHARACTERISTICS

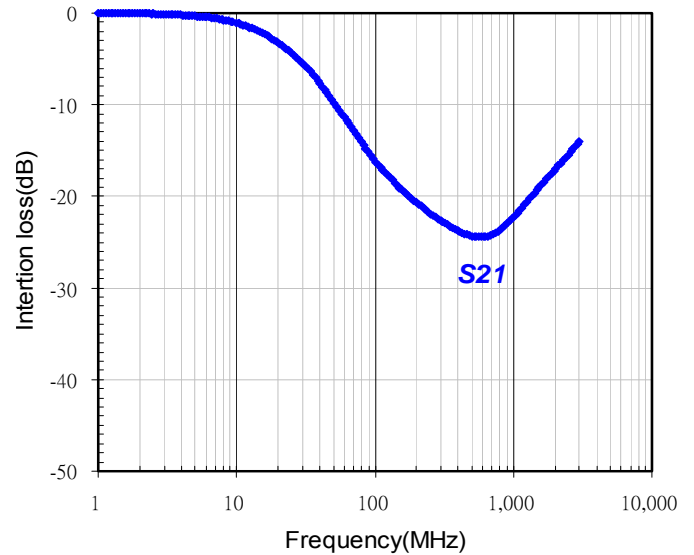
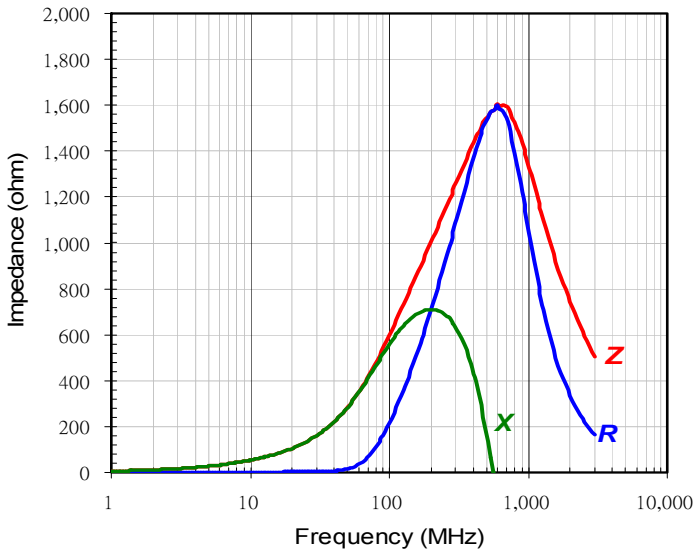

**MGB1005G102**

IMPEDANCE vs. FREQUENCY CHARACTERISTICS

INSERTION LOSS vs. FREQUENCY CHARACTERISTICS

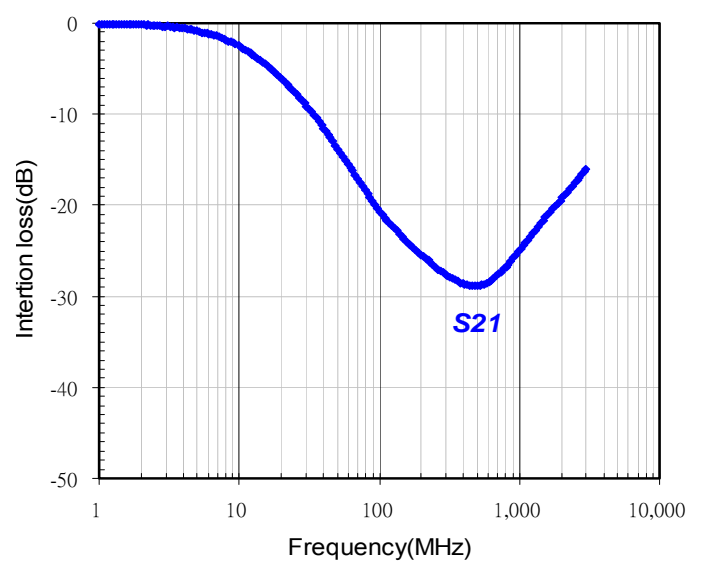
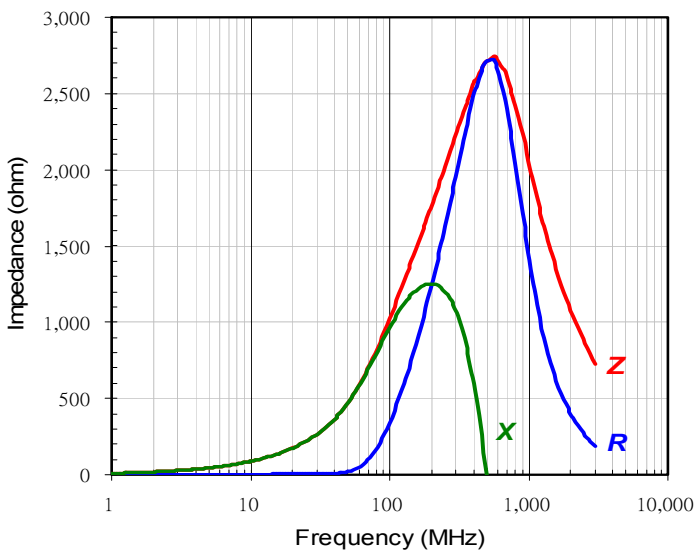

**MGB1005G182**

IMPEDANCE vs. FREQUENCY CHARACTERISTICS

INSERTION LOSS vs. FREQUENCY CHARACTERISTICS

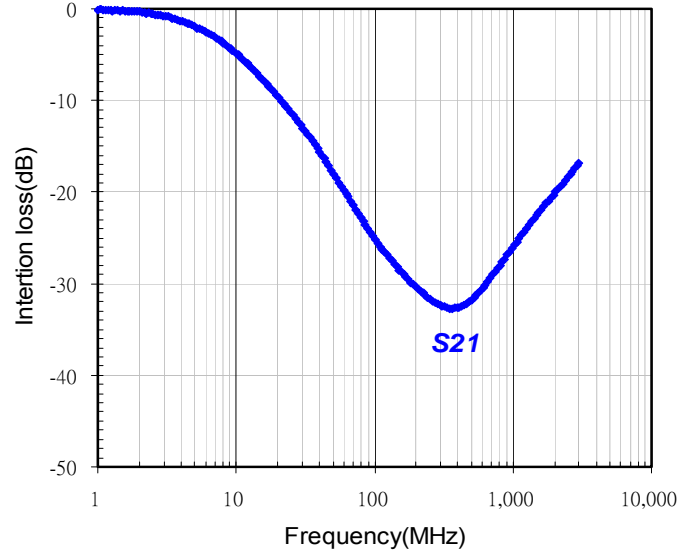
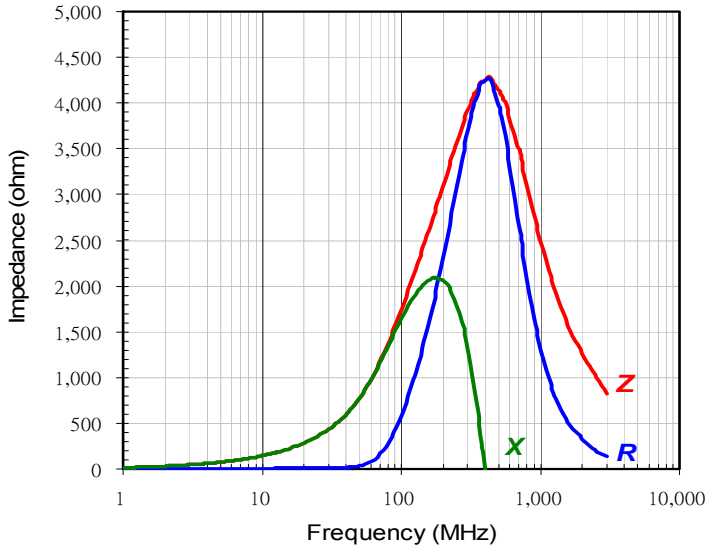

**5. RECOMMENDED SOLDERING CONDITIONS**

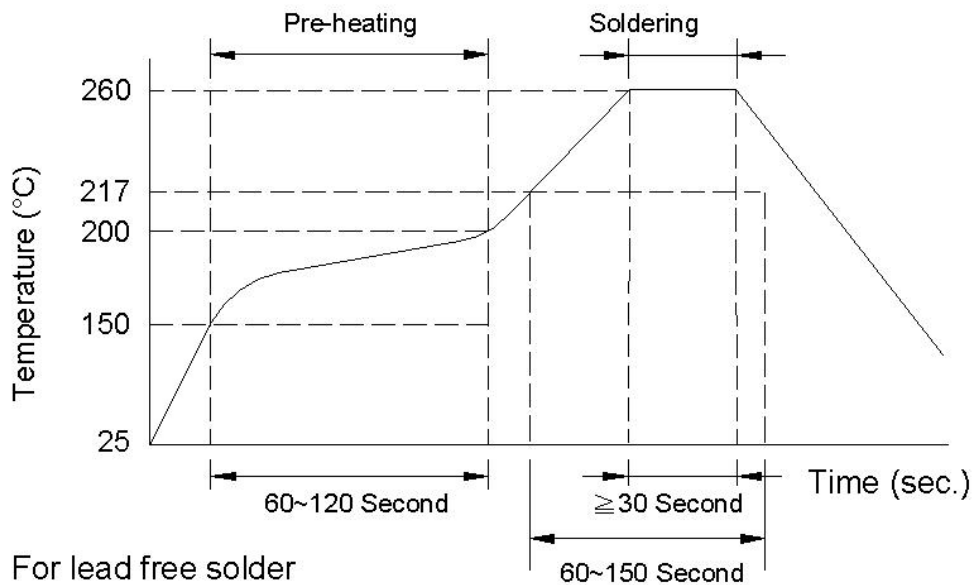

6.LAND PATTERNS FOR REFLOW SOLDERING

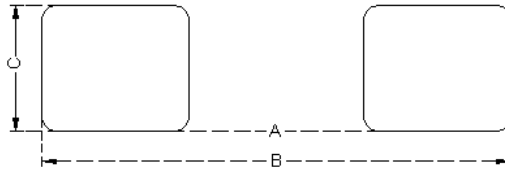

Unit : mm (inches)

Size	A	B	C
1005	0.4 ~ 0.6 (0.015 ~ 0.023)	1.6 ~ 2.6 (0.063 ~ 0.102)	0.4 ~ 0.7 (0.016 ~ 0.027)

7.RELIABILITY AND TEST CONDITION

Test item	Test condition	Criteria
<b>Temperature Cycle</b>	a. Temperature : -40 ~ +85°C b. Cycle : 100 cycles c. Dwell time : 30minutes d. Measurement : at ambient temperature 24 hrs after test completion	a. No mechanical damage b. Impedance value should be within ± 20 % of the initial value
<b>Operational Life</b>	a. Temperature : 125°C ± 5°C b. Test time : 1000 hrs c. Apply current : full rated current d. Measurement : at ambient temperature 24 hrs after test completion	a. No mechanical damage b. Impedance value should be within ± 20 % of the initial value
<b>Biased Humidity</b>	a. Temperature : 40°C ± 2°C b. Humidity : 90 ~ 95 % RH c. Test time : 1000 hrs d. Apply current : full rated current e. Measurement : at ambient temperature 24 hrs after test completion	a. No mechanical damage b. Impedance value should be within ± 20 % of the initial value

Test item	Test condition	Criteria
<b>Resistance to Solder Heat</b>	a. Solder temperature : $260 \pm 5^{\circ}\text{C}$ b. Flux : Rosin c. DIP time : $10 \pm 1$ sec	a. More than 95 % of terminal electrode should be covered with new solder b. No mechanical damage c. Impedance value should be within $\pm 20$ % of the initial value
<b>Adhesive Test</b>	a. Reflow temperature : $245^{\circ}\text{C}$ It shall be Soldered on the substrate applying direction parallel to the substrate b. Apply force(F) : 5 N c. Test time : 10 sec	a. No mechanical damage b. Soldering the products on PCB after the pulling test force $> 5$ N
<b>Steam Aging Test</b>	a. Temperature : $93^{\circ}\text{C}$ b. Test time : 4 hrs c. Solder temperature : $235 \pm 5^{\circ}\text{C}$ d. Flux : Rosin e. DIP time : $5 \pm 1$ sec	More than 95 % of terminal electrode should be covered with new solder
<b>Rated Current Test</b>	a. Apply current : full rated current / 5min	Temperature rise should be less than $25^{\circ}\text{C}$

## 8. GENERAL TECHNICAL DATA

Operating temperature range :  $- 55^{\circ}\text{C} \sim +125^{\circ}\text{C}$

Storage Condition : Less than  $40^{\circ}\text{C}$  and 70% RH

Storage Time: 6 months Max.

Soldering method: Reflow or Wave Soldering

## 9. TAPE AND REEL SPECIFICATIONS

### PAPER CARRIER

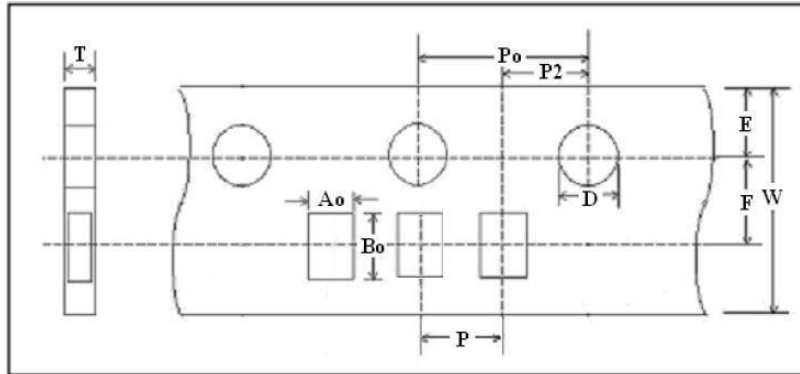

## 10. TAPING DIMENSIONS

Unit: mm

	<b>100505</b>
Symbol	PAPER
W	8.00±0.10
P	2.00±0.05
E	1.75±0.05
F	3.50±0.05
D	1.55±0.05
D1	NA
Po	4.00±0.10
Po10	NA
P2	2.00±0.05
Ao	0.62±0.03
Bo	1.12±0.03
Ko(T)	0.60±0.03
t	NA

11. REEL DIMENSIONS

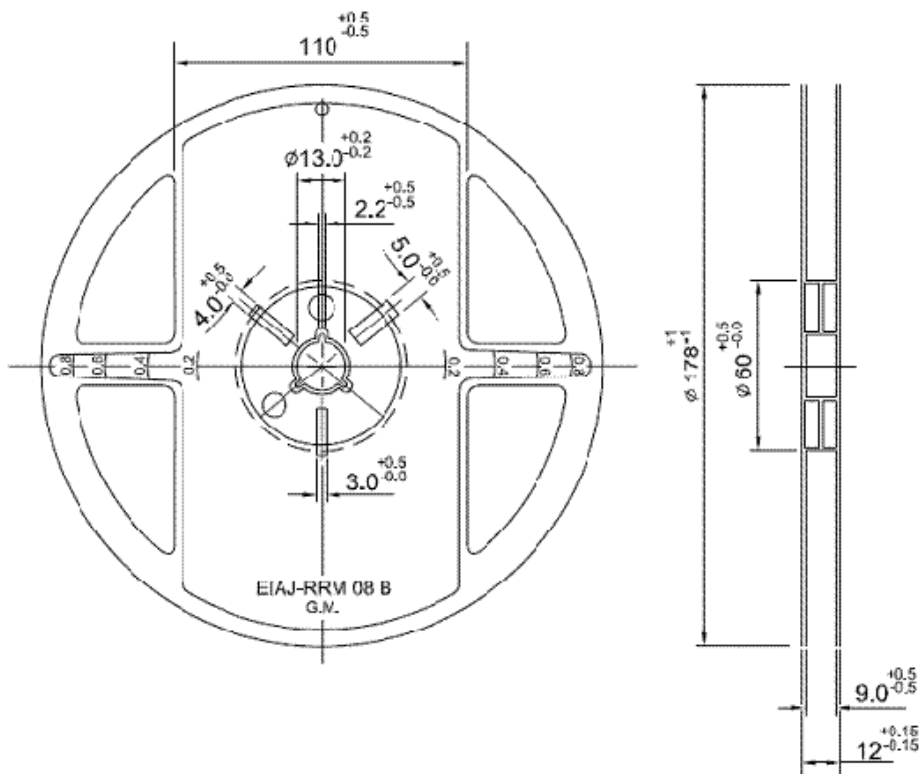

Unit: mm

Reel Packaging Quantity		
PART SIZE (EIA SIZE)		<b>1005</b> <b>(0402)</b>
7" REEL	Qty. (pcs)	10,000

**The Contents of a box :**

1005 (0402): 5 reels / inner box;